

R-625

HYDRAULIC ROTARY RIG



R-625

HYDRAULIC ROTARY RIG

A new model

The hydraulic drilling rig R-625 is mounted on SOILMEC base carrier and has been specially designed for suiting the following applications:

- **cased bore piles with casing driven directly through rotary head or optionally by casing oscillator powered by the base carrier itself;**
- **very deep bored piles stabilized by drilling fluid or dry hole;**
- **CFA pile by means of very long auger string (19,5 m + 6 m extension);**
- **CSP/CAP pile with double rotary;**
- **discrepiles and Soilmixing;**
- **reverse circulation;**
- **it can be converted to work with an hydraulic grab for diaphragm walls.**

The R-625 main features are the following:

- 70 ton class machine;
- new powerful rotary achieving 240 kNm max torque;
- modern electronic instrumentation;
- min. transport weight: 51.5 ton (with tracks, counterweight, rotary and kelly bar removed).

Option features:

- pre-arrangement for casing oscillator;
- central lubrication;
- service winch free-fall option;
- line pull indicator for auxiliary winch;
- crowd winch force monitoring;
- automatic casing drive adapter;
- SOILMEC TRONIC electronic monitoring system on 10" touch screen for monitoring and control of the operating parameters. Memo-block for acquisition of data and software for processing them on PC station. On request data transfer via GSM/GPRS with "calling on trouble" option.

Large diameter bored pile

Max pile diameter	mm	2500
Max cased diameter	mm	2000
Max pile depth	m	77
Max torque	kNm	240
Max drilling speed	rpm	30
Spin off speed	rpm	140
Main winch line pull	kN	240 (opt. 200)
Auxiliary winch line pull	kN	140
Engine	type	DEUTZ BF6M1015C
Power	kW (BHP)	300 (408) @ 2100 rpm
Crowd system	kN	264 / 201
Crowd stroke	mm	6500
Main twin pumps	l/min	2 x 280
Operating weight	tons	70 - 72

Nonroad diesel exhaust regulation compliance (EU-97/68/CE, U.S.A. - EPA; california - CARB)

Continuous Flight Auger (CFA)

Max pile diameter	mm	1200
Max pile depth	m	25,5 (19,5+6)
Max extraction force	kN	732
Machine weight, approx	tons	70

Cased Secant Piles (CSP/CAP)

Max pile diameter	mm	1000
Max pile depth	m	21,5 (15 cased)
Casing pull up/down	kN	320
Second rotary	kNm	162 @ 7 rpm
Max extraction force	kN	732
Max casing speed	rpm	24
Machine weight, approx	tons	75 - 78

Reverse Circulation (RC)

Max pile diameter	mm	2000
Max pile depth	m	50
Max extraction force	kN	360
Machine weight, approx	tons	75

Diaphragm Walls (BH)

Max section (excavation)	mm	3000x1000
Max wall depth	m	50
Max extraction force	kN	256
Machine weight, approx	tons	65 - 68



SOILMEC TRONIC
electronic monitoring system

R-625

MAIN FEATURES

- 1 - Undercarriage** with expandable tracks from 2980 to 4480 mm by means of hydraulic cylinders
- 2 - Turret** c/w DEUTZ BF6M1015C diesel engine and sound proofed canopy, mounted on a 360° slew ring
- 3 - Winch** assembly
- 4 - Parallelogram system** allowing working radius adjustment always maintaining the mast in vertical position. C/w electronic device for automatic stop
- 5 - Self-erecting mast** composed by an intermediate element 13.5 m long and a top element with 1,5 m extension. The max torque can be applied all over the mast length
- 6 - Sheave cathead**
- 7 - Crowd system** by means of 6.5 m stroke hydraulic cylinder
- 8 - Rotary head** with variable displacement motors and one high spin off speed.
- 9 - Telescopic kelly bar** with guide to mast, available with friction or mechanical locking type
- 10 - Self mounting type counterweight** by means of two hydraulic cylinders. It can be easily and quickly removed for transport purpose

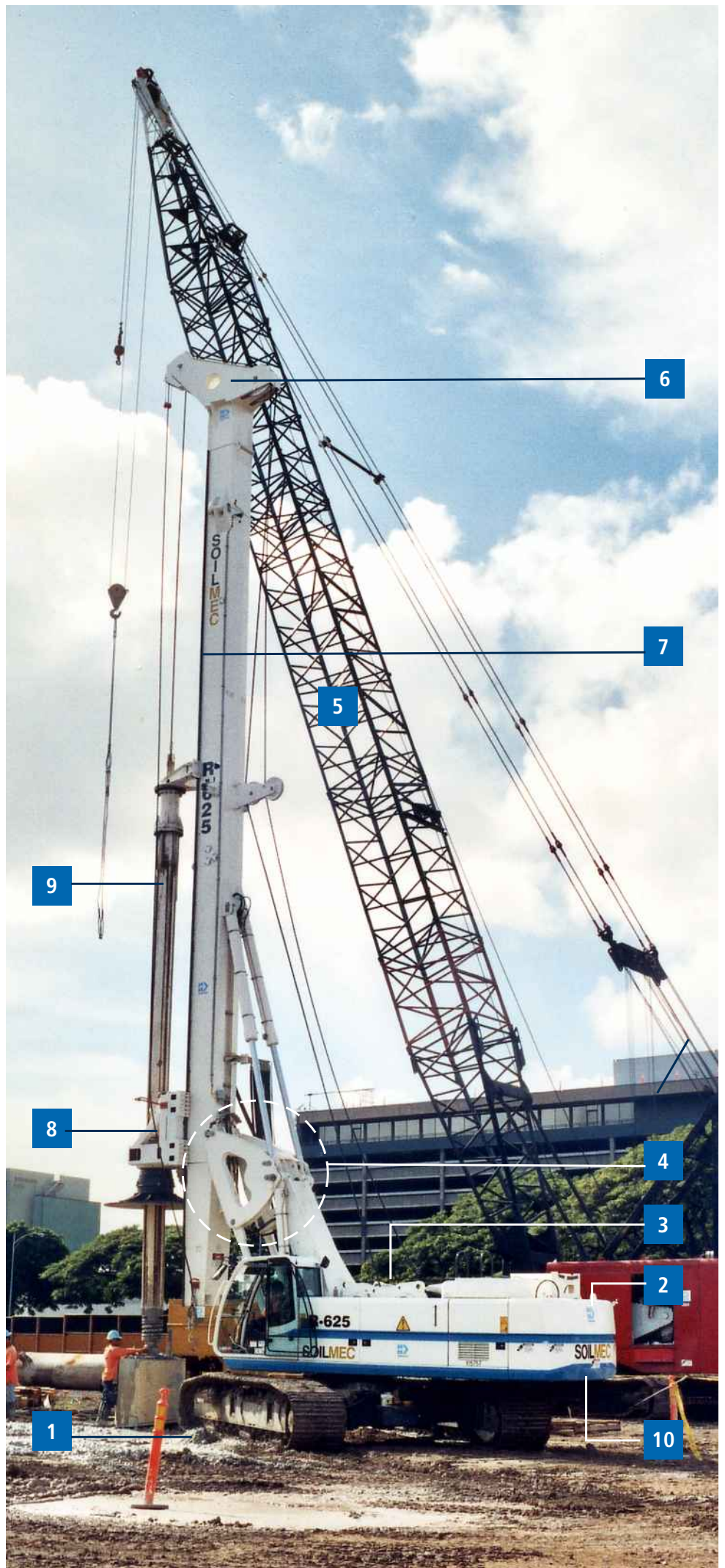

R-625

LARGE DIAMETER BORED PILE

Working Condition

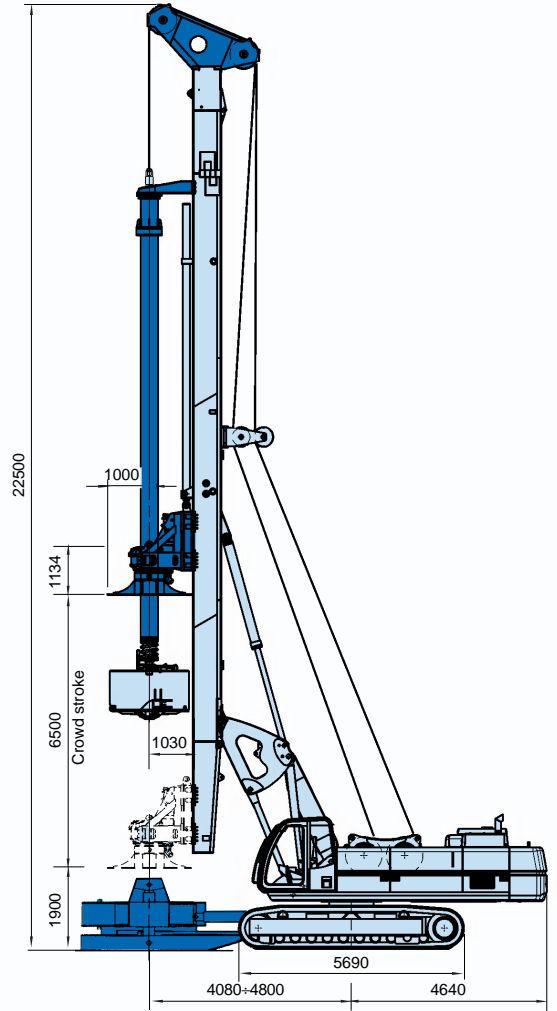
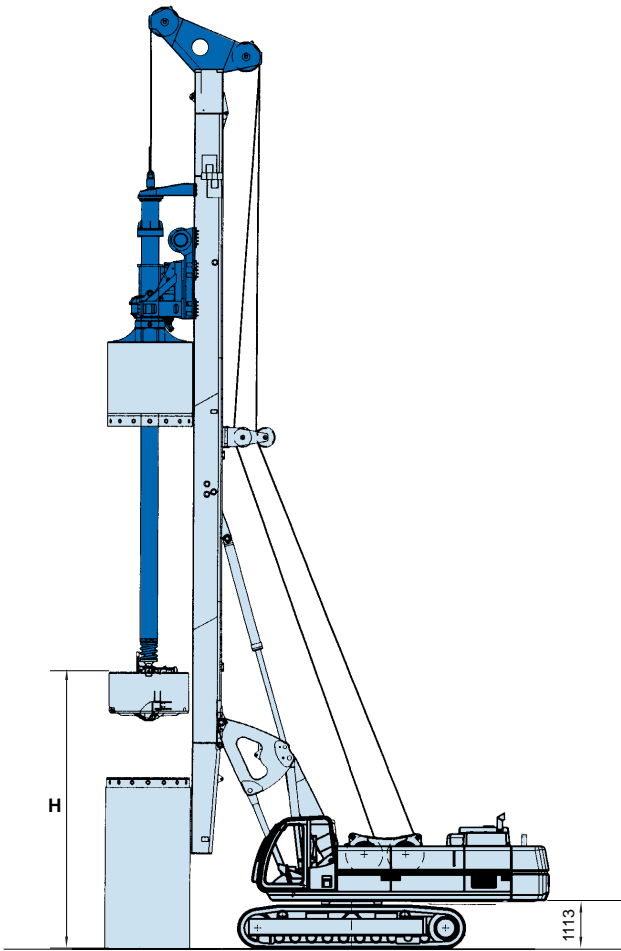

Transport Condition

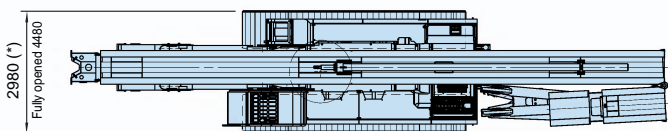

(*) 2500 mm with 700 mm wide shoes and optional undercarriage

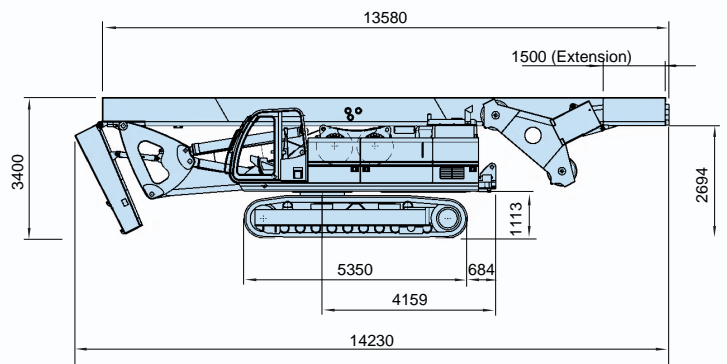

Weights

Weight with 13,5 m mast section and 1,5 m extension only	kg	47.500
Weight without kelly and counterweight (rotary on)	kg	55.000

R-625

CFA-CSP/CAP

Working Condition

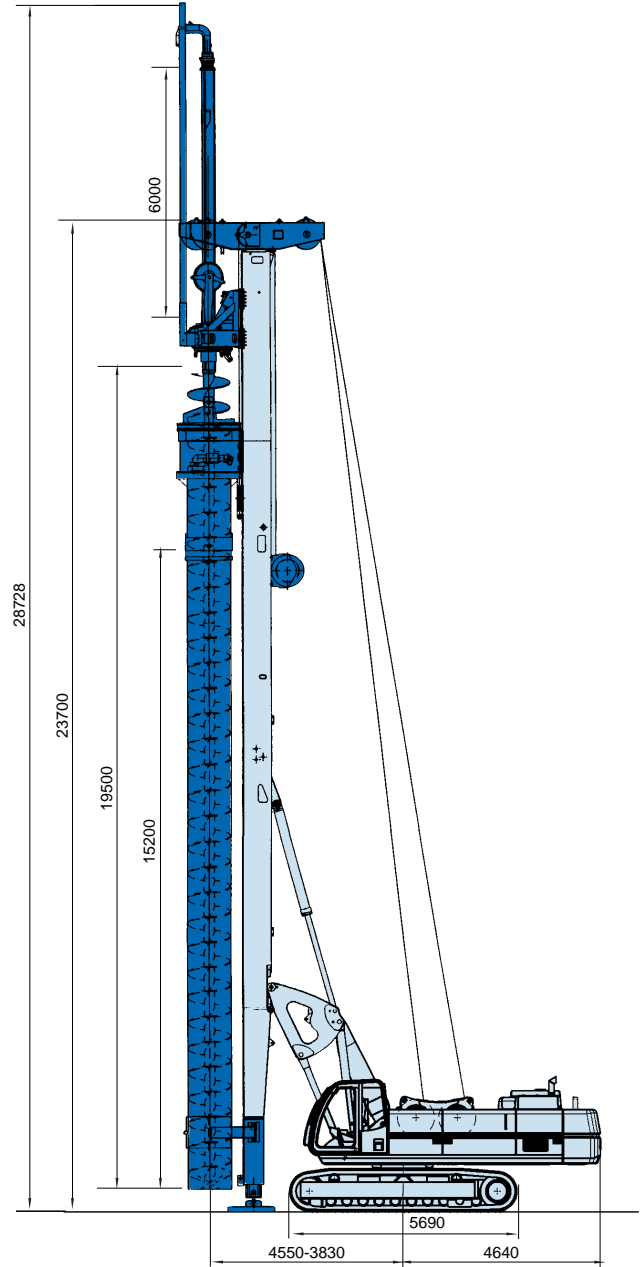
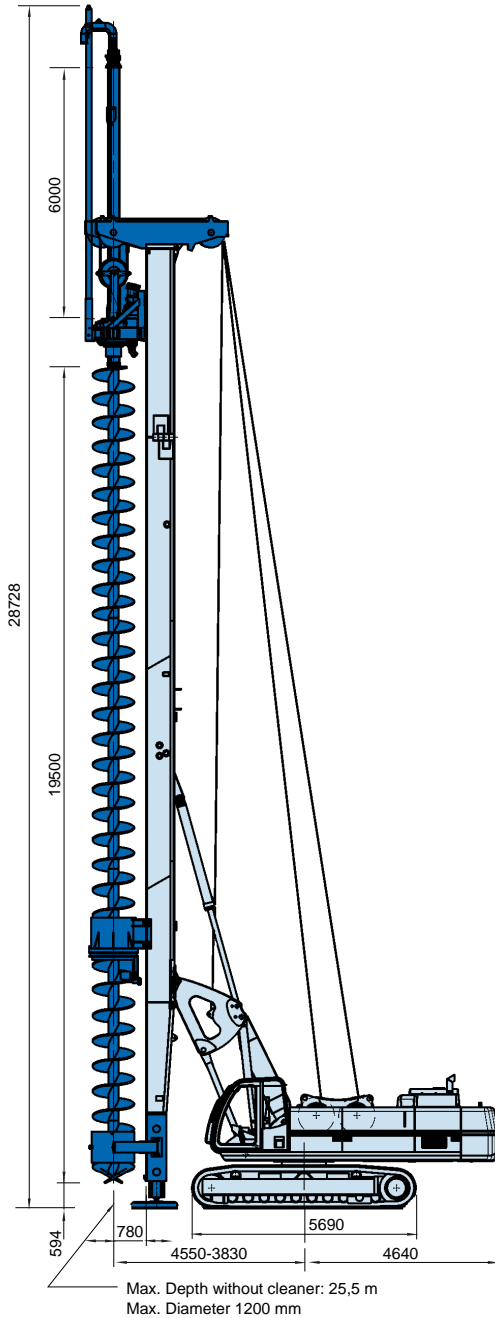

Kelly Bars

Mechanical locking kelly bar – Ø 406 mm

elements n°	length m	depth m	weight ton	H height m
4x	10,5	37,0	5,8	9,2
4x	11,5	41,0	6,3	8,1
4x	13,5	49,5	7,2	6,0
4x	15,5	58,0	8,2	3,9
4x	16,5	62,0	8,7	2,9

Friction kelly bar – Ø 406 mm

elements n°	length m	depth m	weight ton	H height m
4x	10,5	37,0	5,7	9,2
4x	11,5	41,0	6,2	8,1
4x	13,5	50,0	7,1	6,0
4x	15,5	58,0	8,0	3,9
4x	16,5	62,0	8,5	2,9
5x	10,5	46,0	5,5	9,2
5x	11,5	51,5	6,0	8,1
5x	13,5	62,0	6,9	6,0
5x	15,5	72,0	7,9	3,9
5x	16,5	77,0	8,4	2,9

Standard dimension of tool connection is 150x150 mm
H= kelly stub height from ground level

R-625

RC-BH

Working Condition

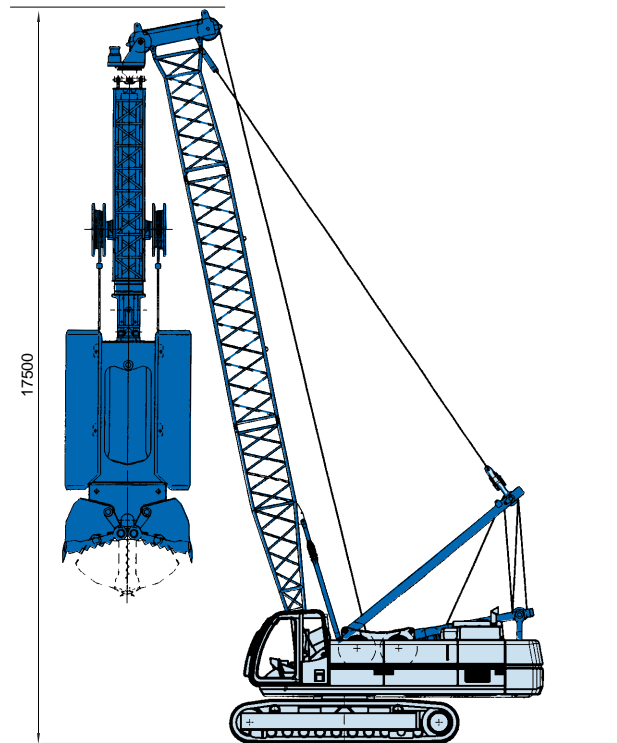
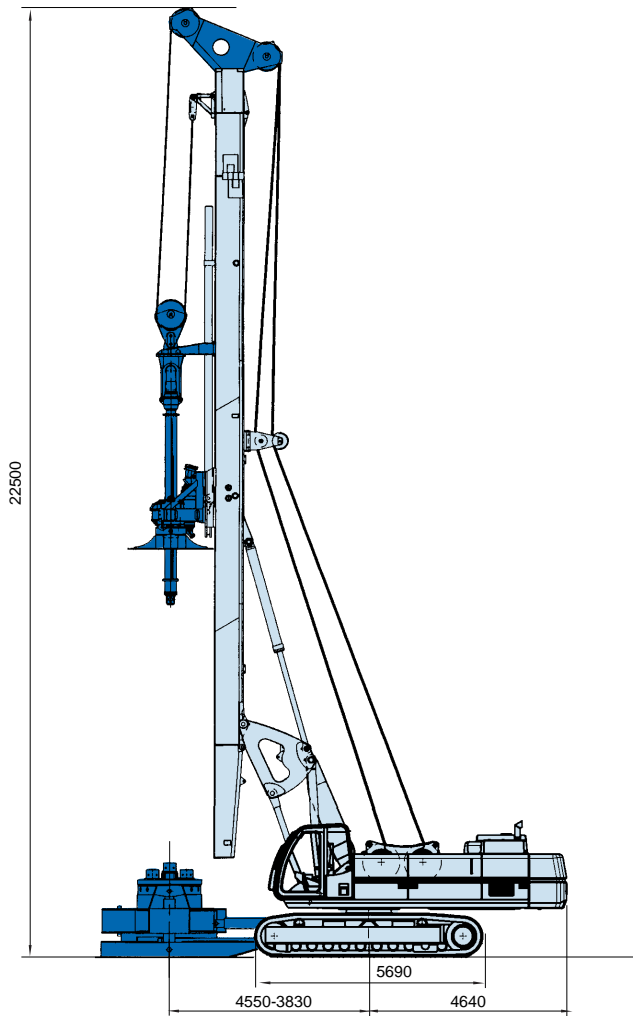

General Dimensions

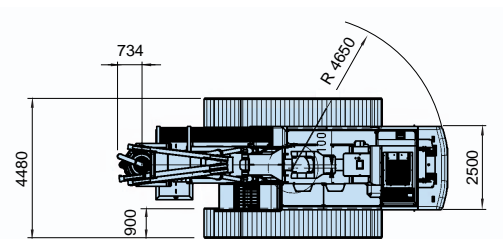
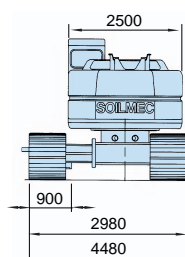

CFA Version



SOILMEC distributes machinery and structures all over the world, supported by SOILMEC subsidiary companies and representative offices as:

SOILMEC LTD - U.K.

SOILMEC MISR S.A.E. Co. - Egypt

SOILMEC (H.K.) Limited - Hong Kong

SOILMEC JAPAN CO LTD - Japan

SOILMEC S.P.A. - Beijing Repr. Office - P.R. China

SOILMEC FAR EAST PTE.LTD - Singapore

SOILMEC EMIRATES - U.A.E.

SOILMEC GULF - U.A.E.

CERTIFIED QUALITY SYSTEM

In 1990 Soilmec was awarded the certification of its own Quality System to ISO 9001/UNI 29001 series standards.



SOILMEC S.p.A.

Ground Engineering Equipment

5819, via Dismano

47023 Cesena (FC) - Italy

tel. +39-0547-319111

fax +39-0547-318548

[http:// www.soilmec.it](http://www.soilmec.it)

e-mail: soilmec@soilmec.it